

User manual  
**4BELL – TRANSPORT CHAIR**

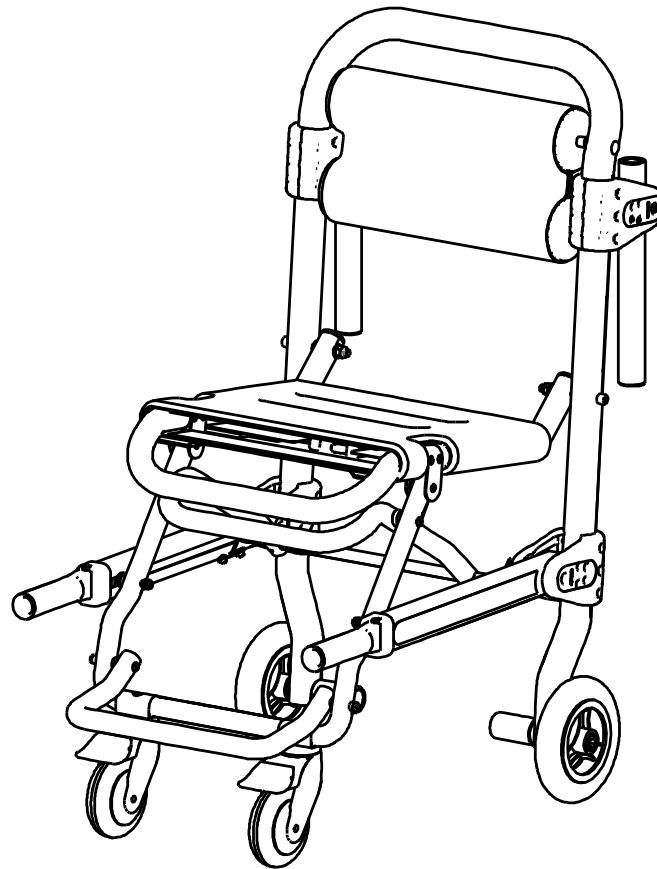

**CE** Class I Medical Device, compliant with the Medical device directive 93/42/EEC

**Warning**

The information contained in this manual is subject to change without notice.

The Diagrams are inserted only for reference and may vary slightly from the actual device.

Spencer Italia S.r.l. assumes no responsibility for any errors contained herein or for damage, accidents or consequences connected with the supply, performance or use of this manual.

First edition: 25/06/2015  
Rev.1 04/09/2015



# INDEX

---

<b>1. MODELS</b>	<b>3</b>
<b>2. INTENDED USE</b>	<b>3</b>
<b>3. REFERENCE STANDARD</b>	<b>3</b>
<b>4. INTRODUCTION</b>	<b>3</b>
4.1    Use of the manual	3
4.2    Labelling and tracking control of the device	3
4.3    Symbols	4
4.4    Warranty and support	4
<b>5. WARNINGS</b>	<b>4</b>
<b>6. SPECIFIC WARNINGS</b>	<b>6</b>
6.1    Physical requirements of operators	7
<b>7. RESIDUAL RISK</b>	<b>7</b>
<b>8. TECHNICAL DATA AND COMPONENTS</b>	<b>8</b>
<b>9. INSTALLATION AND START-UP</b>	<b>8</b>
<b>10. FUNCTIONAL CHARACTERISTICS</b>	<b>9</b>
<b>11. INSTRUCTIONS FOR USE</b>	<b>10</b>
11.1    Medical vehicle requirements	10
11.2    Opening the chair	10
11.3    Rear handles opening, armrests (where present) and footrest	10
11.4    Opening and closing of telescopic handles	10
11.5    Headrest opening (where present)	11
11.6    Parking brakes	11
11.7    Closing the chair	11
11.8    Lifting the chair	12
<b>12. CLEANING AND MAINTENANCE</b>	<b>12</b>
12.1    Cleaning	12
12.2    Precautionary maintenance	12
12.3    Periodic maintenance	14
12.4    Special servicing	14
12.5    Life span	14
<b>13. TROUBLESHOOTING</b>	<b>15</b>
<b>14. ACCESSORIES</b>	<b>16</b>
14.1    Standard equipment	16
<b>15. SPARE PARTS</b>	<b>16</b>
<b>16. DEMOLITION</b>	<b>16</b>

## Warning

The information contained in this document could be modified without any warning and is not to be intended as a commitment on behalf of Spencer Italia S.r.l. Spencer products are exported to many countries and the same identical regulations are not always valid. For this reason there could be differences between the description here described and the product actually delivered. Spencer continually strives to reach the perfection of all items sold. We therefore hope you will understand if we reserve the right, at any time, to modify the shape, equipment, lay-out or technical aspects that are herein described.

© Copyright Spencer Italia S.r.l.

All rights reserved. No part of this document can be photocopied, reproduced or translated into another language without the written approval of Spencer Italia S.r.l.

## 1. MODELS

The standard following models can undergo change, revision and implementation without any notice.

- 4BELL – TRANSPORT CHAIR 4BELL SILVER
- 4BELL AVIO – TRANSPORT CHAIR 4BELL AVIO SILVER

## 2. INTENDED USE

The transport chair 4BELL is a device for transport of patients in sitting position from the rescue place to the ambulance or to another device intended for transport on the vehicle. It is therefore non usable as a device for transport of the patient inside the ambulance.

The device is equipped with wheels that allow easy movement on flat surfaces. If handling with wheels is difficult or considered a risk, the device can be lifted using front and rear handles.

The medical vehicle must be equipped with a dedicated Spencer fixing system that allows storage of the device in the closed position guaranteeing maximum safety.

The patient should not intervene on the device.

## 3. REFERENCE STANDARD

As a distributor or end user of products manufactured and/or marketed by Spencer Italia S.r.l. you are strictly required to have basic knowledge of any legal requirements applying to the devices contained in this supply that are in power in the goods final destination Country (including laws and norms regarding technical specifications and/or safety requirements) and therefore you are strictly required to have the necessary knowledge to guarantee all aspects regarding the total conformity of the products to the regulations in the relevant territory.

RIFERIMENTO	TITOLO DEL DOCUMENTO
UNI EN 1865-1	Patient handling equipment used in road ambulances - Part 1: Specification for general stretcher systems and patient handling equipment
UNI EN 1789 § 4.5.9 - § 5.4.2 - § 5.4.5	Medical vehicles and their equipment - Road ambulances

## 4. INTRODUCTION

### 4.1 USE OF THE MANUAL

This manual is intended to provide the health care operator with the all the necessary information for its safe and appropriate use as well as adequate maintenance of the device.

*Note: The manual is an integral part of the device. It must be kept for the duration of the device and must accompany the device in case of change of ownership or destination. If the operating instructions received relate to products not received, you must immediately contact the manufacturer before use.*

The Spencer product manuals can be downloaded from the website or can be requested by <http://support.spencer.it> or by contacting the manufacturer. Exceptions are items whose essentiality for reasonable and predictable use is such as to make it unnecessary to prepare instructions in addition to the following warnings and directions on the label.

Regardless of the level of experience gained in the past with similar devices, it is recommended that you carefully read this manual before installing, operating or using the product or any maintenance

### 4.2 LABELLING AND TRACKING CONTROL OF THE DEVICE







Each device has got an identification label positioned on the device itself and/or on its box, which includes identification data about the manufacturer, the product, the CE mark, the serial number (SN) or lot number (LOT).

It must never be removed or covered.

In case of damage or loss, request a duplicate from the manufacturer. Failure to do so will interrupt the validity of the guarantee as the device can no longer be traced.

**The Directive 93/42/EEC requires manufacturers and distributors of medical devices to keep track of the device location. If the device was in a different location to the address where it was sent or to where it had been sold, donated, lost, stolen, exported, or destroyed, permanently removed from use, or if the device had not been delivered directly from Spencer Italia S.r.l., register your device at <http://service.spencer.it> or inform the customer (see § 4.4).**

#### 4.3 SYMBOLS

Symbols	Meaning
	General or specific warnings
	Lubricate
	See instructions for use
	Product code
	Serial Number
	The product is compliant with the requirements of Directive 93/42/EEC

#### 4.4 WARRANTY AND SUPPORT

Spencer Italia S.r.l. guarantees that products are without defects for a period of **one year from the date of purchase**.

For any information regarding the correct interpretation of the instruction manual, the use, maintenance, installation and restore of the product, contact the Spencer customer care service ph. +39.0521.541111, fax +39.0521.541222, e-mail [service@spencer.it](mailto:service@spencer.it), or visit <http://it.spencer.it/contatti> to find the nearest service centre for assistance.

In order to facilitate the assistance service, please always indicate the lot number (LOT) or serial number (SN) shown on the label applied on the box or on the device.

**Conditions for warranty and assistance can be viewed on <http://support.spencer.it>.**

*Note: Record and store; these instructions, lot (LOT) or serial number (SN) if any, date and place of purchase, date of first use, date servicing, user names and comments.*

#### 5. WARNINGS

*The warnings, notes and other important safety information are indicated in this section and are clearly visible throughout the entire manual.*

##### **User training**

*Note: Laboratory testing, post production tests, instruction manuals cannot always consider every possible scenario for use. This means that in some cases the performance of the product could be notable different from results to date obtained. Instructions are continually being updated and are under tight surveillance of fully qualified staff with adequate technical formation.*

- Regardless of the level of experience gained previously with similar devices, it is recommended that you carefully read this manual before installing, operating or using the product or carrying out any maintenance. If in doubt, contact Spencer Italia S.r.l. to obtain the necessary clarifications.
- The product must be used by trained personnel only, having attended specific training for this device and not for similar products.
- The suitability of the user to use the product may be attested by the records of training, where the names of those trained, of the trainers, dates and place are indicated. **This register which certifies the eligibility of the operators to use the Spencer device must be kept for a period of 10 years after the disposal of the device itself. This register will be made available to the competent Authorities and/or manufacturer if requested. In the absence of such documentation, sanctions will be applied.**
- Do not allow any untrained person to help during the use of the device, because they could cause damage to the patient or to themselves.
- The product should be operated only by personnel trained in the use of this product and not in others similar.

*Note: Spencer Italia S.r.l. is always at your disposal to organise product training.*

##### **Installers training**

*The installation of the device must be carried out only by qualified and trained staff authorized by Spencer Italia S.r.l. Dates and procedures for participating in training courses will be arranged between the customer and our Commercial offices.*

## **Product functionality**

### **Use of the device in anyway other than described in this manual is forbidden.**

- Before each use, the perfect operating state of the device must be thoroughly checked as specified in the instruction manual. If any damage or abnormalities which could in any way influence the correct functioning and the safety of the device are detected, the device must be immediately removed from service and the manufacturer must be contacted.
- If any failure or incorrect functioning of the device is detected, it must be immediately substituted with a similar item so that the rescue procedures are guaranteed without any interruption.
- The appliance must not in any way be tampered with (modification, adjustment, addition, replacement). In such cases all responsibility for any malfunctions or injuries caused by the appliance itself will be denied; moreover CE certification and product warranty will be considered void.
- Those who modify or have modified, prepare or have prepared medical appliances in such a way that they no longer serve the purpose for which they were intended, or no longer supply the intended service, must satisfy the valid conditions for the introduction onto the market.
- During use, position and adjust the device taking care not to cause any obstruction to rescuers and or any other rescue equipment.
- Ensure that all the necessary precautions are taken in order to avoid the hazards that can arise as the result of contact with blood or body fluids, when applicable.
- For devices intended for the transport of patients, always respect the maximum load capacity of the device, as indicated in this user's manual. Maximum load capacity means the total weight distributed according to the human anatomy. In determining the total loading weight of the product, the operator must consider the weight of the patient, the equipment and the accessories. Moreover, the operator must consider that the overall dimensions of the patient do not reduce the functionality of the device.
- For devices intended for the transport of patients, make sure, before lifting, that operators have appropriate physical condition as indicated in the manual.
- **The maximum weight supported by each rescuer must comply with the requirements prescribed by the law of the land, in the field of Health and Safety at Work.**
- **The warranty seals, where present, must not be removed;** in such case, the manufacturer will no longer recognize the product warranty and will accept no responsibility in case of incorrect operation or damage caused by the product itself.
- Avoid contact with sharp objects
- The installation of the device must be carried out only by qualified and trained staff authorized by Spencer Italia S.r.l. Timing and procedures for conducting training courses shall be agreed between the customer and our Commercial offices.
- Operating temperature: from -10°C to + 50°C

## **Storage**

- The device should not be exposed to or come into contact with any source of combustion or inflammable agents. Store in a cool, dry, dark place and do not expose to direct sun.
- Do not store the device underneath any heavy objects which could cause structural damage.
- Store and transport the device in its original packaging. Failure to do so makes the warranty void.
- Storage temperature: from -20°C to +60°C

## **Maintenance/cleaning**

### **Spencer Italia S.r.l. disclaims any liability for any damage, direct or indirect, which is a result of improper use of the product and replacement parts and / or otherwise of any repairs made by an entity other than the authorized Spencer service centres; this will also invalidate the warranty.**

- The operator must always wear adequate personal protection such as gloves and mask etc. during all checking, maintenance and cleaning procedures.
- Establish a maintenance program and periodic testing, identifying an employee responsible for overseeing. The person to whom the ordinary maintenance of the device is entrusted must ensure the basic requirements foreseen by the manufacturer in the user's manual.
- **The frequency of inspection is determined by factors such as legal requirements, the type of use, frequency of use, environmental conditions during use and storage.**
- Spencer Italia S.r.l. disclaims any liability for any damage, direct or indirect, that is the result of incorrect repairs or use of products made by Spencer Italia S.r.l. Repairs must necessarily be carried out by an authorized Spencer Italia service centre, which in using original spare parts will provide a quality repair service in strict accordance with the technical specifications given by the manufacturer. Spencer Italia S.r.l. disclaims any liability for any damage, direct or indirect, which is a result of improper use of spare parts and/or otherwise of any repairs made by an entity other than the Spencer service centres authorized to repair or make substitutions on this product and parts and/or otherwise of any repairs made by an entity other than the Spencer service centres authorized to do so; the warranty will also be invalidated.
- Use only original components, spare parts and or accessories, approved by Spencer Italia S.r.l., in order to carry out any operation without causing any alteration or modification to the device.
- For any operations that are not carried out directly by the manufacturer but by an authorised centre, we have to underline that a report regarding all operations carried out must be requested. This will permit both Spencer Italia S.r.l. and the end user to keep a log book regarding the operations carried out on the device.
- All maintenance and revision must be recorded and documented with the corresponding report for technical assistance; documentation shall be maintained for at least 10 years from the end of life and must be made available to the competent authorities and/or the manufacturer if requested.

- The cleaning schedule for reusable products must be performed in accordance with the directions provided by the manufacturer in the user manual, in order to avoid the risk of cross-infection due to the presence of secretions and/or residuals.
- The device and all its components, after washing, should be allowed to dry completely before storing.
- If required, lubrication must be carried out after cleaning and complete drying.

### **Regulatory requirements**

**As a distributor or end user of products manufactured and/or marketed by Spencer Italia S.r.l., you are strictly required to have a basic knowledge of any legal requirements applying to the devices contained in this supply that are in power in the final destination Country (including laws and norms regarding technical specifications and/or safety requirements) of the goods and therefore you are also strictly required to have the necessary knowledge to guarantee all aspects regarding the total conformity of the products to the regulations in the relevant territory.**

- Promptly notify Spencer Italia S.r.l. (already during the first product enquiry) when requesting in details regarding any revisions to be made by manufacturer in order to guarantee the conformity of the products to the territory's legal specifications (including those resulting from rules and/or norms of other kind).
- Act, with all due care and diligence, and contribute to ensure conformity to general safety requirements of all devices marketed in the territory, by providing final users with all necessary information for carrying out periodical checks on their devices, exactly as specified in the relevant user's manual.
- **Actively contribute to safety checks on product** sold, by communicating any relevant risk analysis information both to the manufacturer and to any competent authorities so that the necessary action can be promptly taken.
- The distributor or final user is aware that in the event of any failure to conform to the above mentioned requirements you will be deemed fully responsible for all damages that might occur. Therefore Spencer Italia S.r.l. expressly disclaims any responsibility and/or liability for your non-compliance with the present regulatory provisions.

### **General warnings for medical devices**

**The user must carefully read not only these general warnings, but also those listed below.**

- It is not foreseen that the use of the device is prolonged beyond the time necessary for the first responders to complete their operation and the subsequent stages of transport to the nearest rescue point.
- When the device is being used, the assistance of qualified staff must be guaranteed and at least one operator must be present.
- Follow the procedures and protocols approved by the internal organization.
- The activities of disinfection and sterilization should be carried out in accordance with the parameters given in the validated cycle as specified in the technical standards.
- With reference to the D. Lgs. 24th February 1997, n. 46 emended by D. Lgs. 25/01/2010, n. 37 – Acknowledgement of Directive 93/42/CEE and 2007/47/CE concerning Medical Devices, we remind both public and private operators, , That in the exercise of their activity detect an accident involving a medical product are required to notify the Ministry of Health, under the terms and in the manner established by the relative ministerial decrees and also to the manufacturer. Health care providers whether public or private are required to communicate to the manufacturer, any other inconvenience that may allow for the adoption of measures to ensure the protection and health of patients and users

## **6. SPECIFIC WARNINGS**

**For the use of the *Transport Chair 4BELL*, , the user must have read, understood and follow carefully all the instructions described in this manual**

- Follow the procedures approved by the Emergency Medical Service for the immobilization and transport of patients.
- Follow the procedures approved by the Emergency Medical Service for the positioning and transport of patients.
- Do not use if the device or its parts are pierced, torn, frayed or excessively worn out.
- The device can be used with a patient only if the belts are intact and properly fastened
- Handling of the device on the wheels, is permitted only with all four wheels resting on the floor. Is not permitted to carry the chair tilted or with it resting on only two wheels.
- When the device is moved with the patient on it, is essential to have a firm grip on the handles adapt to the type of transport.
- The device can be lifted using front and rear handles. Before lifting, make sure that the front handles are fully extended and locked.
- Before use, ensure that all operators have a firm grip on the device.
- Avoid pulling the device on rough surfaces.
- Do not lift by crane or other mechanical lifters.
- Do not use drying machines.
- The device is intended to be used for patient transport as stated in the chapter Intended use and **cannot be used as a parking device or for the transport of patient inside the ambulance.**
- Practice with an empty chair in order to become familiar with the manoeuvres is recommended.
- For patient loading techniques, for particularly heavy patients, for working on uneven ground or in special and unusual circumstances, the presence of more operators is recommended (not only 2 as required in standard conditions).
- Before each use, check the integrity of the belts and their hooks as specified in the user's manual. In case of malfunction or damage that may compromise the functioning and safety of the device, patient or operator, it is necessary to replace the belts.
- Make sure the belts are properly fastened to the frame/patient board of the stretcher.
- Make sure that the tapes used to fix the seat fabric are properly secured.

- Always immobilize the patient, using the straps supplied by the manufacturer; lack of immobilization may cause serious damage. The manufacturer is not liable for any damage caused by improper or incorrectly applied belts.
- Do not operate in case the weight has not been distributed correctly.
- Use only the handles or knobs to lift the chair and not any other parts of the device.
- **Hold the chair firmly still when occupied by the patient.**
- **The Stationing brakes are aids for the operator, they do not in any way substitute his supervision.**
- Great attention must be paid to any possible obstacles (water, ice, debris, etc.) on the route of the stretcher/chair, because they could cause loss of balance of the operator and compromise the proper functioning of the device. If the path cannot be freed of obstacles, choose an alternative route.
- To avoid injury, before lifting the chair, always check that the lifting handles are securely locked and fully extended.
- It is preferable not to use the device in the event of suspected cervical or spinal trauma, or fractures.
- To avoid any risk to the safety of the patient and rescuer, during transport on the stairs, the presence of at least two operators is necessary.
- Condensation, water, ice and dust accumulation can affect the correct functioning of the device, making it unpredictable and causing a sudden change in weight that operators have to sustain.
- For obstacles higher than 10mm the device must be lifted using the handles. Impact against obstacles above this height, can compromise the integrity and security of the device.
- Do not alter or modify the device arbitrarily: the modification may cause unforeseeable functioning and damage to the patient or operators. In any case the warranty will be void and the manufacturer relieved from any liability.
- When closing the device, make sure nothing interferes with the handling systems. Carelessness during this operation could be the cause of crush injuries.
- The 4BELL transport chair, is fulfils the requirements of the EN 1789 standard if used with a Spencer fastening system compliant to the standard. Therefore, the use of fastening systems is not permitted unless approved by the manufacturer. Fastening systems that have not been approved may alter the structural and functional characteristics of the device.

## 6.1 PHYSICAL REQUIREMENTS OF OPERATORS

The 4BELL transport chair is a device intended for professional use only. Each operator must be trained to transport patients safely and efficiently. Do not allow untrained persons to help operators during use of the product, as this may cause injury to themselves or to other people.

The operators that use the device must have the physical ability to use it and good muscle coordination, as well as presenting a strong back, arms and legs to raise and support and be able to grasp the device firmly with both hands.

**Operators must be able to provide the necessary assistance to the patient.**

**Users should be able to lift and handle safely the weight of the chair and the patient as well as any other equipment used with the device .**

**During loading procedures of extremely heavy patients, operations on rough terrain or in particular circumstances, the presence of more operators may be needed (not only 2 as required in normal conditions)**

**The ability of all operators must be considered before determining their role in the use of the chair.**

## 7. RESIDUAL RISK

The residual risks listed below have been identified exclusively in reference to the intended use of the device.

- The use by untrained personnel may result in injury to the patient, rescuer or others.
- Inadequate disinfection procedures may involve cross-infection risks.
- Failure to immobilization the patient on the device or immobilization performed using incomplete belt systems or incorrectly fixation to the chair, can result in serious injury to the patient.
- Partial extraction of front handles could cause their sudden closing when lifting the device. Make sure the handles are fully extracted and locked before lifting.
- Patient intervention on the device and its closing and braking mechanisms can cause unlocking of the device from open position or unexpected movements with consequent risks for the patient. Make sure the patient does not intervene on any element of the device.
- Failure to close handles when their extraction is not required can cause obstruction during device handling. Make sure the handles are closed when moving the device on wheels.
- Partial opening of the chair can cause its unexpected closure if lifted with consequent risks for the patient. Always verify the proper insertion of the locking system.
- The use of fixing systems not approved by the manufacturer may result in instability of the device inside the ambulance, causing the risk of violent impact of the device against people and/or things
- Failure to comply with warnings given to operators, can cause crushing when during handling of mechanisms.
- **Failure to read and understand the instructions of 4BELL, can have consequences for the patient and operators.**

## 8. TECHNICAL DATA AND COMPONENTS

*Note: Spencer Italia S.r.l. reserves the right to make changes to specifications without prior notice.*

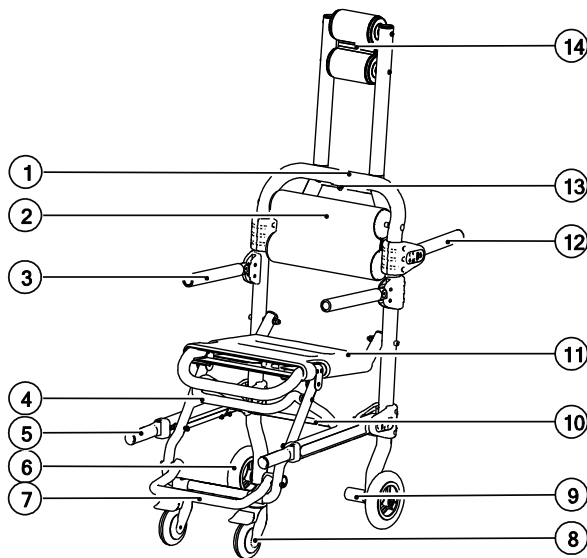

N°	Description	Material
1	Transport handle	Alluminium
2	Backrest	PVC/PE exp
3	Armrests	Al/Rubber
4	Closure system unlock lever	Al
5	Telescopic handles	Al/Rubber
6	Rear wheels	PU
7	Footrest	Steel
8	Front wheels	Rubber/PP/PA
9	Pin for coupling with fixing system	Nylon
10	Crossbar to unlock closure system	Steel
11	Seat	PVC/Nylon
12	Rear handles	Al/Rubber
13	Lever to lock/unlock headrest	Steel
14	Headrest	PVC/PE exp

All 4BELL chairs are characterized by an aluminum frame. Armrests and headrests are available on specific versions of 4BELL. The device is supplied with two belts attached to the seat and to the backrest.

The technical specifications of the basic model are as follow:

Feature	
Length opened w/handles closed	710 ± 5 mm
Length opened w/handles opened	1080 ± 5 mm
Width	485 ± 5 mm
Height opened	905 ± 5 mm
Dimensions folded	270x485x915 ± 5 mm
Rear wheels	ø150 mm
Front wheels	ø100 mm
Weight	9,4 ± 0,2 kg
Loading capacity <sup>1</sup>	180 kg

<sup>1</sup> Maximum load capacity means the total weight distributed according to the human anatomy. In determining the total load of the weight on the product, the operator must consider the weight of the patient, the equipment and the accessories.

## 9. INSTALLATION AND START-UP

Before the first use verify that:

- The packaging is intact and has protected the device during transport
- Check that are present all the components included in the accompanying list.
- Functionality of the device according to the user manual
- The ambulance is equipped with a dedicated Spencer fastening system and its installation will not hinder access to any other devices.
- Sheets and belts are properly fastened. It is important to make sure that the buckles under the seat are properly inserted and the velcro bands fully adhere to each other.
- Upper belts are properly fixed to the backrest.

Do not modify for any reason any part or component of the chair as this may cause injury to the patient and/or rescuers.

**If conditions mentioned above are not satisfied, the device cannot be considered secure, safe use is compromised and it is a possible cause of injury for patient and operators and can cause damage to the device.**

Practice with a chair without patient before the regular start-up.

**For instructions on use after start-up, follow the operations described on paragraph 12.**

If the above conditions are met, the device may be considered ready for use; otherwise you must immediately remove the device from service and contact the manufacturer..

Do not alter or modify in any way the appliance; any such interference could cause malfunctions and injury to the patient and/or rescuer. Moreover the manufacturer will no longer recognize the product warranty and will accept no responsibility.



**10. FUNCTIONAL CHARACTERISTICS**

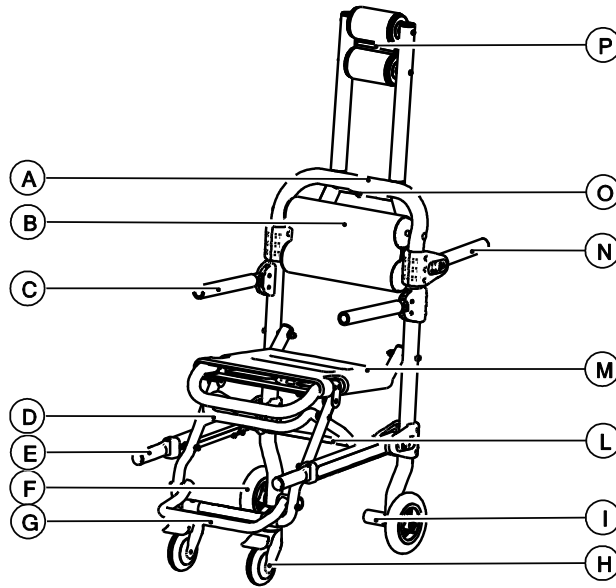

Element	Description	Function
<b>A</b>	Transport handle	To safely push the chair
<b>B</b>	Backrest	In coated PVC. Removable and washable and increases patient comfort during transport by giving extra support to patient's back.
<b>C</b>	Armrests	Not present in the basic model, they improve lateral containment of the patient and allow resting of arms
<b>D</b>	Closure system unlock lever	Lifting it with one hand in the direction of the seat frame, locking system of the chair unlocks it.
<b>E</b>	Telescopic handles	They can be used to lift the chair with patient in position. They are equipped with an automatic locking system and a manual unlock mechanism which is activated by pushing downwards
<b>F/I</b>	Rear wheels/Pin for coupling with fixing system	Characterized by large diameter, allow optimal handling on most common surfaces. On the same axis of the wheel, are pins used to place the chair on the dedicated fastener
<b>G</b>	Footrest	Foldable support for patient's feet
<b>H</b>	Front wheels	Allows easy handling of the chair. They are equipped with brakes for rotation and axis, minimizing the rescuer's effort during short stationing and that may be needed during recovery operations.
<b>L</b>	Crossbar to unlock closure system	It performs the same function as the component "D". With this element, the activation can be performed with the foot.
<b>M</b>	Seat	Essential support for the patient, it is equipped with integrated removable belts fixed on the lower side by velcro straps.
<b>N</b>	Rear handles	They can be used by the operator placed on the rear side of the chair in order to lift the chair. The operator on the front side, will simultaneously lift the front of the chair using the telescopic handles.
<b>O</b>	Lever to lock/unlock headrest	It is present in models equipped with headrest. It allows locking of the headrest in raised position and is manually activated.
<b>P</b>	Headrest	Provides greater support to the patient. It is particularly useful for tall patients. It is equipped with a band for fixation of the head and when folded does not increase overall dimensions of the chair.

## 11. INSTRUCTIONS FOR USE

Before transferring, lifting or transporting the patient, primary medical evaluations have to be performed. Once the diagnosis has been assured, it is preferable (if possible) to suggest to the patient that he actively collaborates during transfer onto the stretcher, and to make sure the patient is fully aware of all risks. Before loading the patient, place the device near the patient; always maintain the safety belts fastened during the manoeuvres.

### 11.1 Medical vehicle requirements

When placed inside the ambulance, the chair 4BELL must be properly anchored in order to limit risks for occupants of the vehicle linked to violent movements resulting from rapid acceleration or deceleration of the vehicle. For this purpose, it is essential to use the dedicated fastening system 4BELL MAX. For its installation, it is necessary that the emergency vehicle is equipped with suitable surfaces to hold safely the assembly consisting of fastener and chair.

4BELL MAX User Manual contains more details about requirements of support surfaces and installation.



**Failure to use 4BELL MAX or its improper installation can seriously affect the patient's and operator's safety.**

### 11.2 Opening the chair

The 4BELL transport chair is maintained in closed position thanks to the belts on the backrest (par 11.7). Before opening the chair, release the quick release buckle of the upper belts.

Firmly hold the transport handle, press on the frame of the seat as shown by the arrow, until all the wheels rest on the floor. Firmly press down the seat frame until the locking system is activated.

Check visually that the terminal part of the cross bar has reached the end of the slot placed on the sliding profile of the telescopic handles.

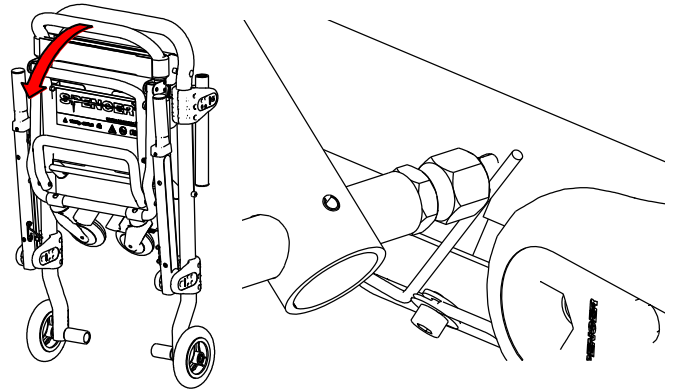

### 11.3 Rear handles opening, armrests (where present) and footrest

Rear handles and armrests (if present), can be opened by turning them as shown by the arrows. When no longer needed or when the chair is no longer in use, they can be closed by rotating in the opposite direction.

Similarly, open the footrest by rotating it outwards until it is completely opened.

After use, close the footrest by rotating in the opposite direction until it is completely closed.

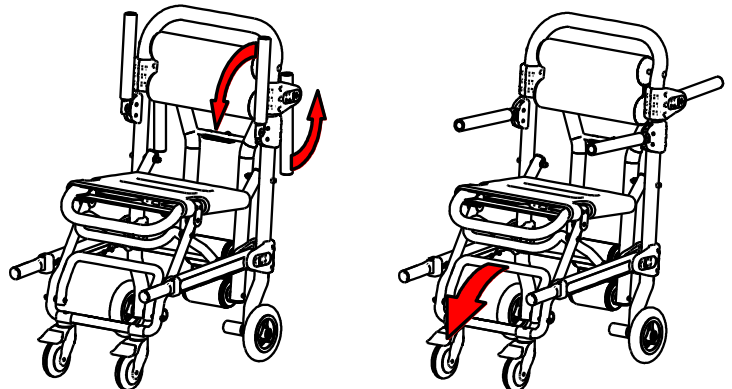

### 11.4 Opening and closing of telescopic handles

The telescopic handles have been made to facilitate lifting of the chair. They are kept in position by a mechanism that is inserted automatically when reaching the excursion limits both during opening and closing.

To unlock the mechanism allowing handle movement, press downwards and move simultaneously.

Pull the handles until they are fully open. It is essential to verify that the locking system has been properly inserted.

To do this, try to slide repeatedly the handles without applying pressure downwards. There must be no movement.

**DO NOT LIFT THE CHAIR IF THE HANDLES ARE NOT COMPLETELY EXTRACTED AND LOCKED.**

Similarly it is possible to close the telescopic handles verifying that they are locked in closed position.

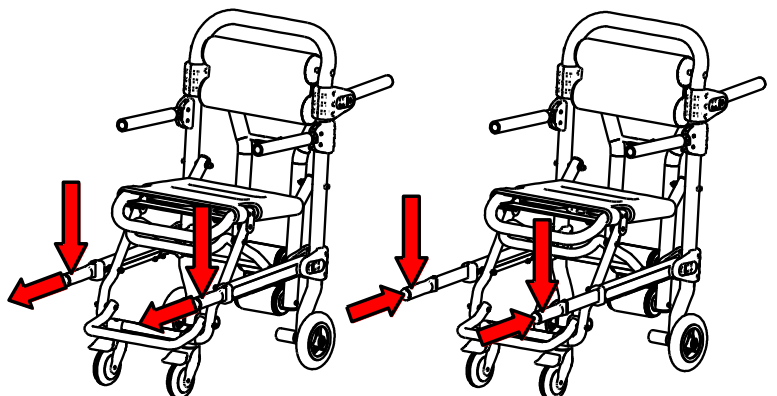

**11.5 Headrest opening (where present)**

To open the headrest, grasp it from the terminal part and rotate until it comes in contact with the top handlebar of the chair. The pin on the release lever must fit into the slot located on the underside of the handlebar. To close the headrest, pull up to release the lever and rotate the headrest downwards accompanying it in the rotation until rest position is reached.

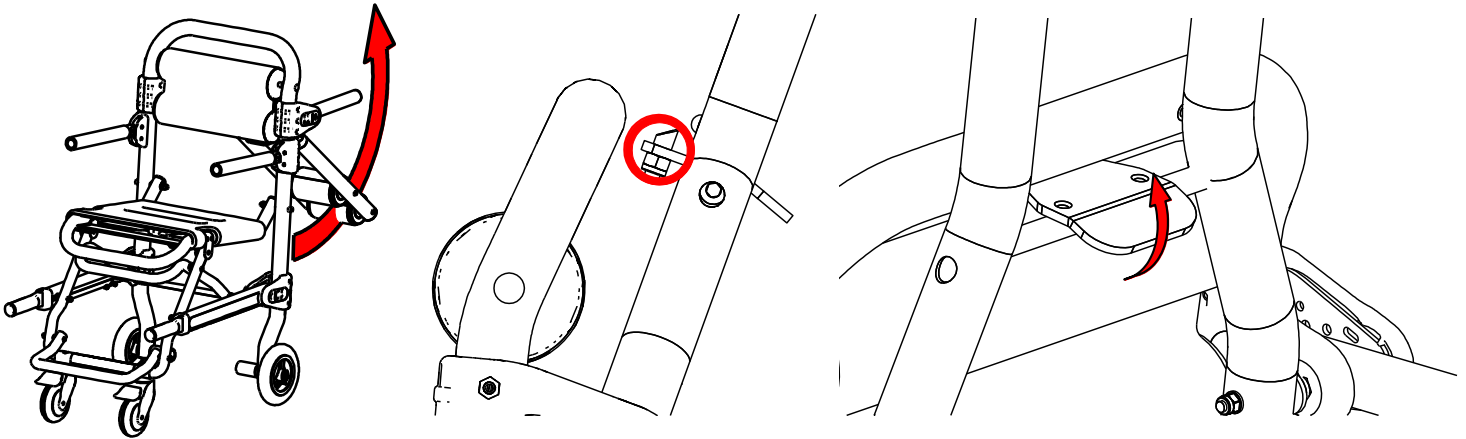

**11.6 Parking brakes**

The 4BELL chair is equipped with brakes that lock both rotation and pivoting. The brake can be operated by pressing with one foot on the lever at the top of the wheel assembly.



**Always insert both brakes**

Lift the levers to release the brakes.



During any handling or working operation with the patient on the chair, the operator must have a firm grip on the device, regardless to the brakes being activated or not.

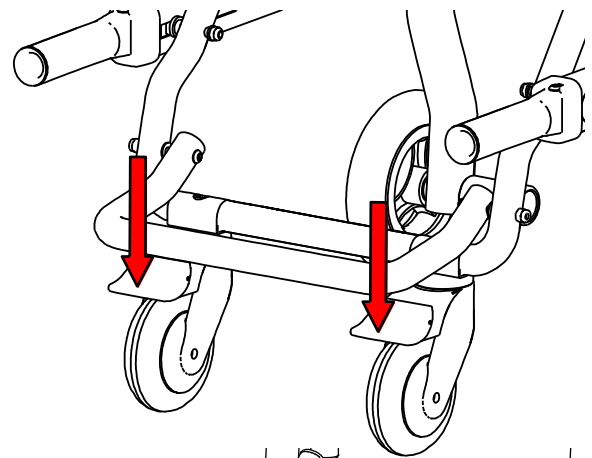

**11.7 Closing the chair**

Place all the handles, headrest and armrests in closed position.

Using one hand, raise in the direction shown by the arrow 1, until the part A of the frame is almost in contact with the part B of the seat frame. This movement will disengage the locking system of the chair.

Then lift the seat until it touches the backrest.

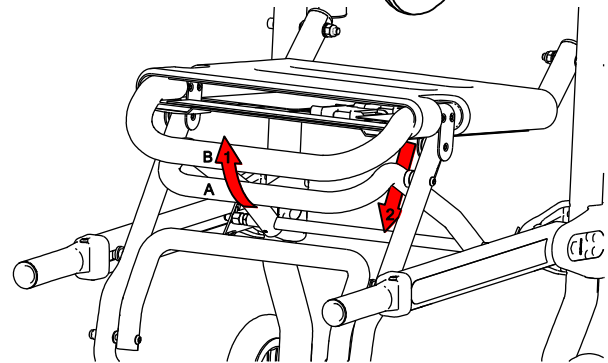

The front wheels will be positioned automatically. It is also possible to disarm the locking system by pressing on the crossbar accessible from the back of the chair as shown by arrow 2. This method could be more difficult due to the reduced space available caused by the presence of the second crossbar.



**The application of excessive force on this component could damage it beyond repair.**

Before placing the chair on the fixing system, it is recommended to secure it in closed position using the integrated belts anchored to the chair backrest.

The belts must pass through free space between the handles and the frame of the backrest and must be attached at the level of the grips of the telescopic handles.

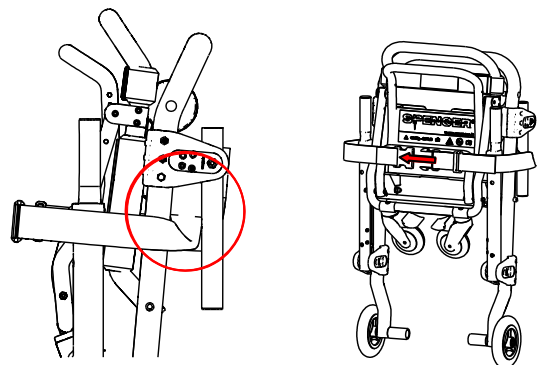

### 11.8 Lifting the chair

To carry the chair on stairs or on surfaces where the use by wheels could be difficult, it is possible to lift the device using the telescopic handles and rear handles. For this method of transport the presence of more operators is required with at least one at the front side and at least one on the back side of the chair.

 **Before lifting it is fundamental to verify that telescopic handles are fully extended and locked as described in par. 11.4.** Failure to control could cause serious injury to patient and operators due to the sudden closure of the telescopic handles. Once on a surface allowing transport on wheels, is recommended to place the chair on the ground in order to avoid placing unnecessary load on operators.

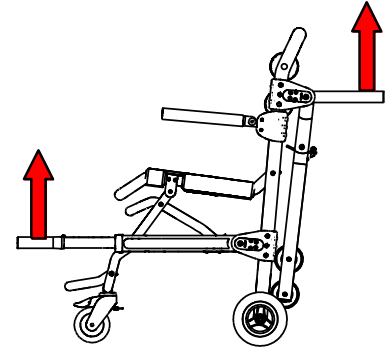

## 12. CLEANING AND MAINTENANCE

### 12.1 CLEANING

Failure to carry out the correct cleaning routine could increase the risk of cross infection, due to presence of body fluids and/or residuals. The operator must always wear adequate personal protection such as gloves and mask, etc. during all checking and cleaning procedures.

The exposed metal parts are usually treated and/or painted in order to increase their resistance to external agents. Clean the exposed parts with water and a delicate soap; **never use solvents or stain removers.**

Rinse thoroughly with warm water making sure that you have removed all traces of detergent, which could ruin or compromise the integrity and durability of the device. **The use of high pressure water should be avoided** because water penetrates in the joints removing the lubricant and creating the risk of corrosion of components. Allow the device to dry thoroughly before storing. Drying after washing or after use in wet environments must be natural and not forced; do not use flames or other sources of direct heat.

If the device needs to be **disinfected**, use products that do not have corrosive or solvent action on the materials of which the device is made. Be sure to take every precaution to ensure that there is no risk of cross-infection or contamination for patients and / or operators.

To maintain the polished appearance of the frame parts we recommend the use of Spencer STX 99 polish cleaner or in alternative creme or wax normally used for polishing car bodywork.

### 12.2 PRECAUTIONARY MAINTENANCE

Establish a maintenance programme and periodic testing routine and identify an employee responsible for this. The person to whom the ordinary maintenance of the device is entrusted must ensure that the basic requirements foreseen by the manufacturer in following paragraphs are inspected.

All maintenance and periodic servicing activities must be registered and kept together with the servicing reports. These documents have to be kept for a period of 10 years after the disposal of the device itself. This register will be made available to the competent authorities and/or manufacturer if requested.

Routine maintenance of the device must be carried out by operators in possession of specific qualifications, trained and experienced in the use and maintenance of the device.

The operator must always wear adequate personal protection such as gloves and mask, etc. during all checking and cleaning procedures.

Checks to be carried out before and after each use and at deadline indicated above, are as follows:

- General functionality of the device
- Cleanliness of the device (remember that the failure to clean could be the cause of cross infections)
- Correct fixation of all nuts, bolts and screws
- Absence of cuts, holes, tears on the structure, including the straps
- None of the tubes or metal sheets present bends or cracks
- The seat or the backrest has no structural damage or cracks
- The seat belts, sheets, moving parts, wheels and handles are intact and functioning properly.
- Lubrication of moving parts
- Wearing on wheels and breaking system
- The wheels are correctly fixed, they are stable and turn properly
- The wheels are free from debris.
- The device opens and locks properly
- The device unlocks and closes properly
- Functioning of springs
- The patient's immobilization belts are present and they are intact and functioning.
- Telescopic handles can be positioned, folded and locked properly in all positions as described in this manual.
- Headrest (if present) works and locks properly
- Verify the functionality of the system which locks the chair in open position. If you try to close the chair without actioning the unlocking system, the chair must not close.
- The emergency vehicle is equipped with a Spencer fastening system intended for the chair
- The connection of the two devices is always correctly inserted and safe.

**The inspection frequency is determined by factors such as local legal requirements, the type of use, frequency of use, environmental conditions during use and storage.**

The only part that needs to be lubricated and must be lubricated at least once a month, is the guides of the locking system of the chair.

Lubrication of other components or parts is not required.

Before lubricating any part, be sure to remove any dust or dirt in the area.

Please note that you must do the cleaning as described in this manual and verify functionality before and after each use. Spencer Italia S.r.l. declines any responsibility for the improper functioning or injury caused to the patient or user by the use of devices that have not been subjected to a routine maintenance programme which will void the warranty and the compliance to the Medical Device Directive 93/42/CEE..

**Every 2 years** the seat and backrest PVC sheets and patient belts must be substituted.

### 12.2.1 Seat belts and sheet replacement

The seat belt is fixed to the sheet by means of straps.

Tear off the belt from the seat.

Open up Velcro closure on the side of the protection sheet that covers the quick release buckles on the lower side of the seat sheet.

Unclip the quick release buckles

Pull the sheet from the front of the chair.

Install the new sheet and belts following the above steps in reverse order. Pay attention that all buckles are correctly engaged and all the straps adhere properly.

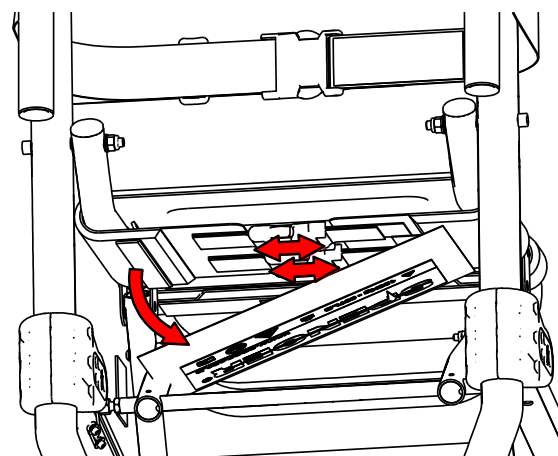
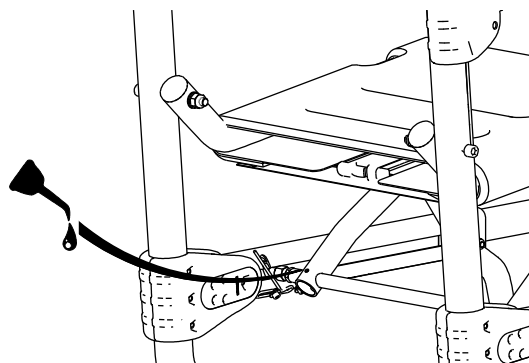

### 12.2.2 Backrest sheet replacement

The sheet of the backrest is secured only by velcro bands. Detach the end of the sheet on the rear side of the backrest and replace it with the new one.

### 12.2.3 Upper belts replacement

This operation requires the use of a 10mm socket wrench and a 5mm Allen key.

Unscrew the nut and screw as shown in the picture.

Assemble the new belts paying attention to the position of the plastic component where the nut is housed. This component must be inserted in the metal buttonhole of the belt and in the rear handle support.

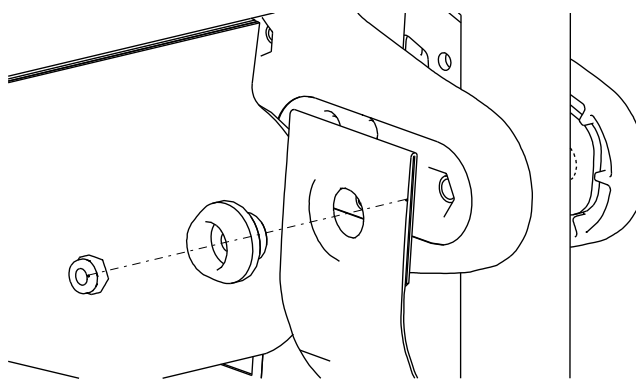
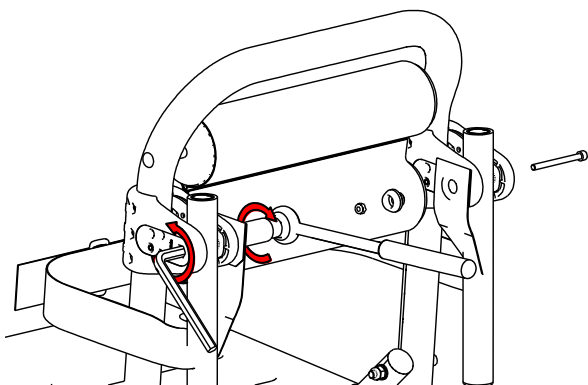

Use only accessories/original spare parts approved by Spencer Italia S.r.l. Failing to do so, we will accept no responsibility for the incorrect functioning and/or damage caused by the use of any device which has not been repaired, or certified on expiry date by the manufacturer or by one of the manufacturer's authorised service centres. Warranty will be considered void in compliance with the Medical Device Directive 93/42/EEC.

### 12.3 PERIODIC MAINTENANCE

**The device must be serviced by the manufacturer or by an authorised centre, every year.**

If the correct revision procedure is not completed, the CE branding will no longer be considered valid and the product will no longer be compliant with the 93/42/CE Directive for Medical Devices and consequently it will no longer be considered compliant with the safety standards declared by the manufacturer at time of purchase.

Spencer Italia S.r.l. will take no responsibility about the incorrect functioning or any damage caused by a device that has not undergone regular revision.

For any operations that are not carried out directly by the manufacturer but by an authorised centre, we have to underline that a report regarding all operations carried out must be requested. This will permit both Spencer Italia S.r.l. and the end user to keep a log book regarding operations carried out on the device.

### 12.4 SPECIAL SERVICING

**Only the manufacturer or centres with written authorisation are authorised to complete any special servicing operations.**

For any operations that are not carried out directly by the manufacturer but by an authorised centre, we have to underline that a report regarding all operations carried out must be requested. This will permit both Spencer Italia S.r.l. and the end user to keep a log book regarding operations carried out on the device.

The end user is authorised to replace only the spare parts indicated in the paragraph 15.

### 12.5 LIFE SPAN

**The device, if used as indicated in the instruction manual, has an average life span of 5 years starting from the purchase/installation date.**

**PVC sheets, seat belts and backrest have to be replaced every 2 years commencing from the purchase/installation date**

The life span can be expanded only if a general revision of the product has been carried out by the manufacturer or by a centre authorised by the manufacturer. Spencer Italia S.r.l. will accept no responsibility for the incorrect functioning and/or damage caused by the use of any device which has not been repaired or certified on expiry date by the manufacturer or by one of the manufacturer's authorised service centres and will consider void both the guarantee and the conformity to the Medical Devices Directive 93/42/CEE

### 13. TROUBLESHOOTING

PROBLEM	CAUSE	SOLUTION
The seat sheet doesn't support the patient's weight	The quick release buckles are not properly engaged	Verify the proper closure of the buckles placed on the lower side of the sheet
	Worn cloth	Replace the sheet as described in the manual
The telescopic handles don't lock in closed or opened position	The telescopic handles have not been completely extracted or inserted.	Extract or insert the telescopic handles until the end position is reached
	The locking system is damaged.	Put the chair immediately out of service and contact the service centre
The headrest doesn't lock in open position	The locking system has not been correctly inserted	Make sure that the pin described in paragraph 11.5 fits into the socket on the handlebar. Check also that no element of the locking lever is damaged. If anomalies are present, put the device immediately out of service and contact the service centre
Front wheels are not automatically positioned	The self-positioning spring has been lost or is damaged	Contact the service centre. The problem does not require that the device is put out of service
The brakes do not work	Worn wheels or damaged mechanism	Put the chair immediately out of service and contact the service centre
The rear handles are unstable or deform under loading	Handle assembly damaged	Put the chair immediately out of service and contact the service centre
The device is difficult to move on wheels or is not stable	One or more wheels are damaged	Put the chair immediately out of service and contact the service centre
When placed on the fixing system, the chair is not stable or doesn't remain closed	The coupling between the chair and the fastener was not done properly.	Consult the users manual of the fixing system
	The fixing system in use is inappropriate for the chair.	Put the device out of service and replace the fixing system with an appropriate one
The spare sheets haven't enough tension or can't be installed because are too tight	The purchased sheets are for the narrower or the wider models	Contact your dealer to obtain the correct item

## 14. ACCESSORIES

---

### 14.1 Standard equipment

**ST10432B** 4BELL FIXATION SYSTEM MAX 10G TESTED

## 15. SPARE PARTS

---

**RIST006A** SPARE SHEETS SET FOR 4BELL CHAIR

**RIST007A** SPARE BELTS SET FOR 4BELL CHAIR

## 16. DEMOLITION

---

When the device is no longer suitable for use, if they haven't been contaminated by any particular agents, they can be disposed of as normal solid waste. Otherwise follow the current regulations for demolition.